

AZ80ES

TUNNEL DE SECHAGE POUR ATR A ENTREE GAUCHE

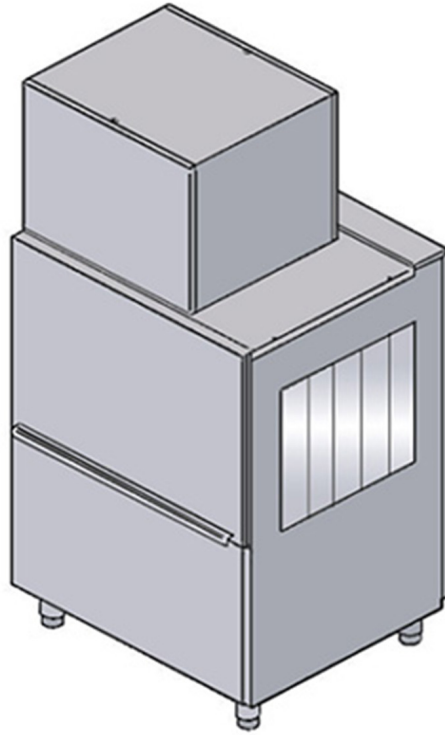

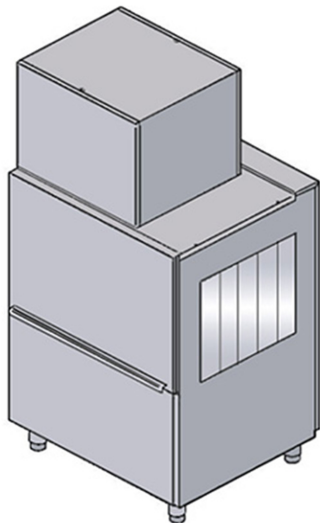

CARACTÉRISTIQUES TECHNIQUES

Largeur: 900 mm
Profondeur: 800 mm
Hauteur: 2010 mm
Volume: 1.27 m³
Puissance électrique: 9.75 kW
Alimentation: 230 V / 3 - 400 V / 3+N/ 50 Hz

